

The Product.

Hydraulic Cylinder

Our direct acting hydraulic ram is not only unique, but is indicative of it's "state of the art" design capability.

The chain synchronised ram which is available in up to four stages can literally "pull itself up".

This revolutionary ram design has made it possible to introduce more straightforward and cost effective installation techniques which allow the ram to be located directly on to a basement floor, or in a shallow lift pit.

Full Synchronisation

The ram is telescopic and is actually a series of steel tubes fitting one inside the other with the largest tube on the outside and uniquely at the top. Synchronisation is achieved by means of a simple system of chains and sprockets. The chains have a 10:1 safety factor. However, a chain breakage value is incorporated, which prevents undesired piston motion in the unlikely event of chain breakage.

Easy Inspection

An important feature is the extremely effective seal design which ensures that virtually no oil leaks occur.

Central Rams Versus Side Acting Rams

Locating the hydraulic ram in the centre beneath the lift car does not offer any real advantage, but rather creates preventable problems and costs, both during installation and later on for the building owner.

Why? Because for it to be possible to locate a traditional telescopic ram underneath the lift car, a deep hole has to be bored in the ground beneath the lift pit into which the lift ram can be fitted. The hole is not only expensive to bore but it can also cause problems in the drainage of water, condensation and leaking oil.

In addition, the ram is inaccessible for a complete visual inspection. Should anything happen to the part of the ram which is below ground, it is rarely noticed until a more dramatic symptom

demands attention. Often in cases like this, the ram has to be completely withdrawn for the fault to be rectified and then re-fitted.

Time consuming, expensive and above all, totally unnecessary when there is now a technology which offers all the advan-

tages of the telescopic hydraulic ram without the need to accept such drawbacks.

Other problems created by bore holes are environmental with soil contamination through oil leakage and the danger of damaging existing electric cables and gas or water pipes.

Our Advantages

Our solution is to locate the ram adjacent to the lift shaft wall. This offers several advantages - the most important of these is cost.

- No ropes or chains are employed for lifting.
- No deep borehole is required, just a lift pit.

Also the incorporation of our unique patented pawl device offers the combined features of:

- Safety gear
- Buffers
- Anti-creep and levelling device

It also provides the facility for:

- Mechanically looking at floor level when required for truck loading.
- Easy to release trapped passengers

Other advantages are:

- Technology which is simple and cost effective to install.
- Easily installed in existing buildings.
- Improved reliability resulting in less maintenance.
- Technical superiority.

A Commitment to Quality

We are committed to maintaining high levels of quality in materials and production. The ram is made of high tensile steel which is turned, ground on a centreless grinding machine and polished.

The surface treatment is intended primarily to provide effective rust protection for all sliding surfaces, but at the same time, produces a more tightly sealed ram with a longer life for the sealing sleeve.

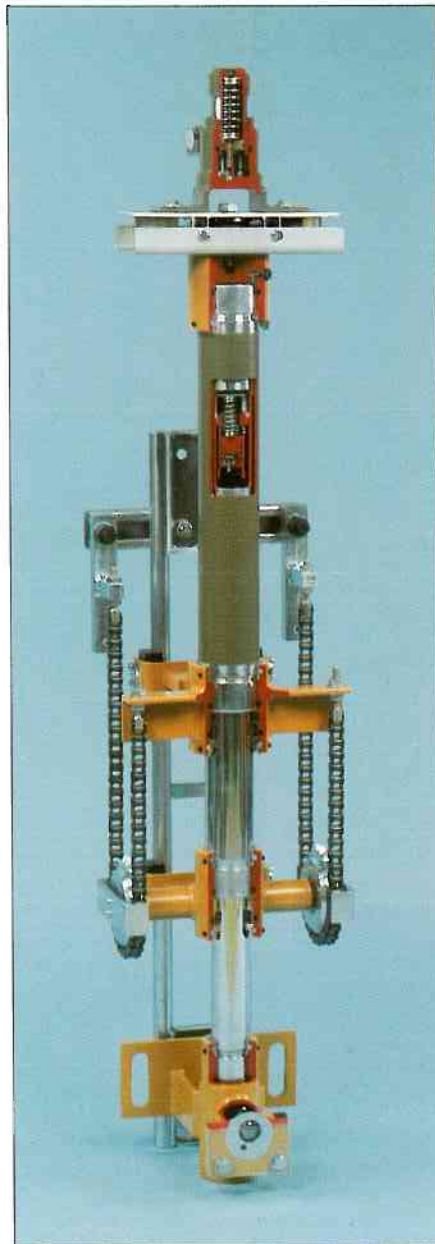

A typical two-stage cylinder arrangement.

Heavy Duty Goods Lifts Up To 40 Tonnes.

The technology employed by us is based on an exceptionally well defined and flexible modular system which is both advanced in it's concept and yet more economical than competitor systems which often require more specialised building work.

In purely practical terms it offers the lift designer a number of options which may be used in order to match the latest technology with customer requirements to produce the optimum solution.

Standardised Components

In engineering terms, the limit of the lifting capacity of a hydraulic ram is determined by:

- The area of the ram
- The oil pressure in the hydraulic system
- The lift travel (ram length)

The total load to be lifted is not therefore a factor. Each cylinder carries it's own load and is dimensioned accordingly for this load.

The total capacity of the lift is determined by the size and number of the rams. The number of cylinders required is calculated by dividing the total force by the lift force of each ram.

This means that whatever the load required, we can offer a solution using standard components and modules. If, for example, a load of 20 tonnes plus a static load which is assumed to be of the same magnitude, i.e. total load of 40 tonnes is to be lifted through a travel approximately 20 metres and at a speed of 0.2 m/s, there are several possible combinations.

Our designers would endeavour wherever possible, to choose standard rams of the same diameter which are placed in pairs symmetrically around a guide. In this imaginary example 24 four stage rams of the second largest diameter from the standard range have been chosen to give a static hydraulic pressure of 3.2 MPa.

Designing using standard modules enables the designers to produce a quick and proven solution with built in flexibility for further changes to the parameters. For example, lift travel, load etc.

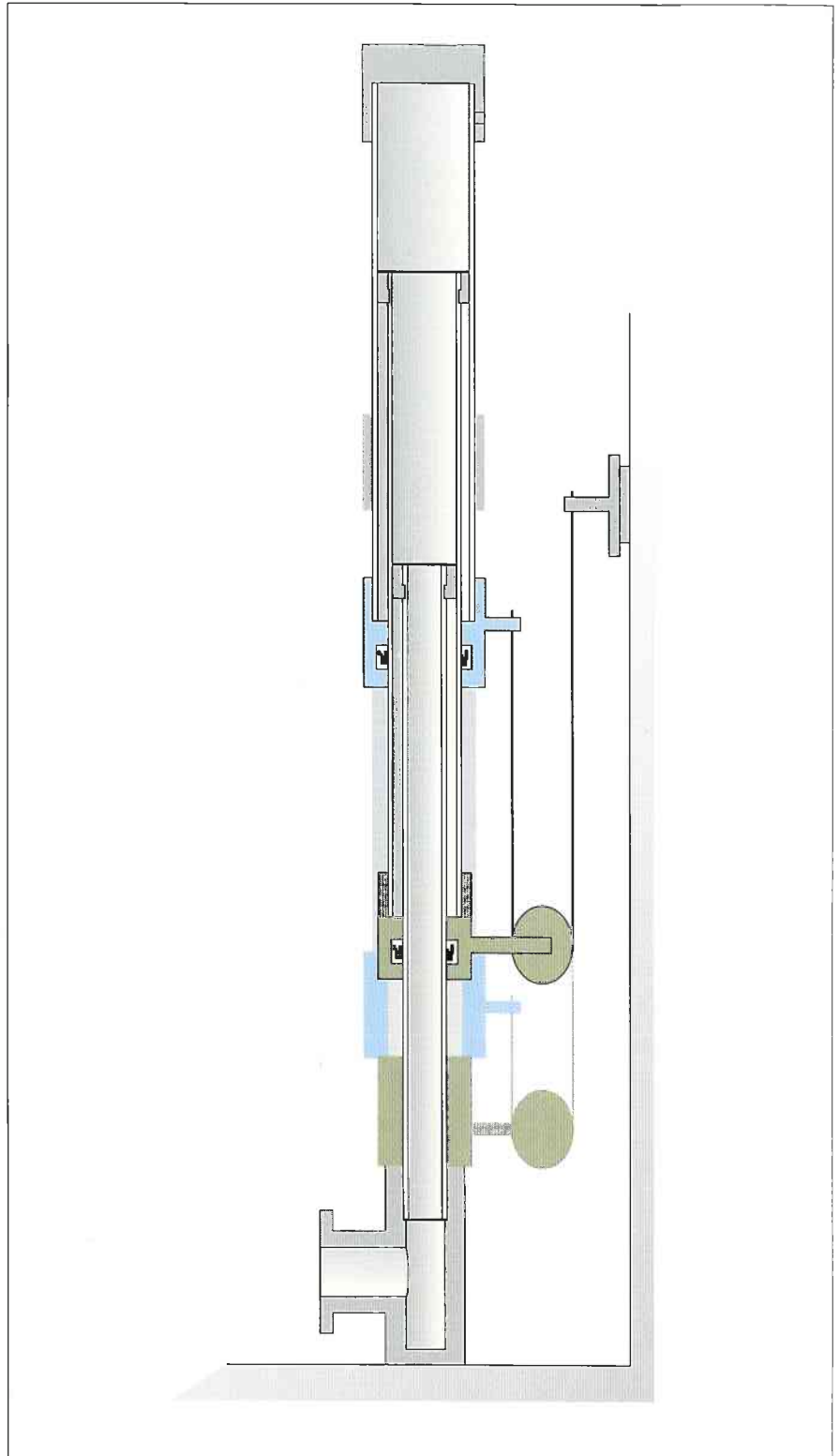

When a lift starts off from it's base position, it is the largest cylinder which moves first. This pulls the chain, which in turn pulls with it cylinder number two steplessly in the ratio 1:2. The movements are fully integrated and smooth. The system offers many advantages including an exceptionally smooth ride, small power losses and high efficiency. The lift can be kept well serviced at all times, since it easy to check it's operation visually, and gain access if any action is to be taken. The whole cylinder with all the peripheral functions is readily accessible for inspection and maintenance.

PAWL DEVICE



PAWL DEVICE (Hydraulically Cushioned)

The "PAWL DEVICE" is one of the safety device provided for hydraulic lift by the European rules. It has two main functions:

- It prevents car sinking in case of oil leakage or oil volume variation.
- It keeps the car steady in case of feeding pipe bursting.

The "PAWL DEVICE" is complete with hydraulic cushioning system assuring a deceleration lower than "gn" ($9,81 \text{ m/s}^2$) giving an alternative to the traditional pit buffer.

PAWL DEVICE

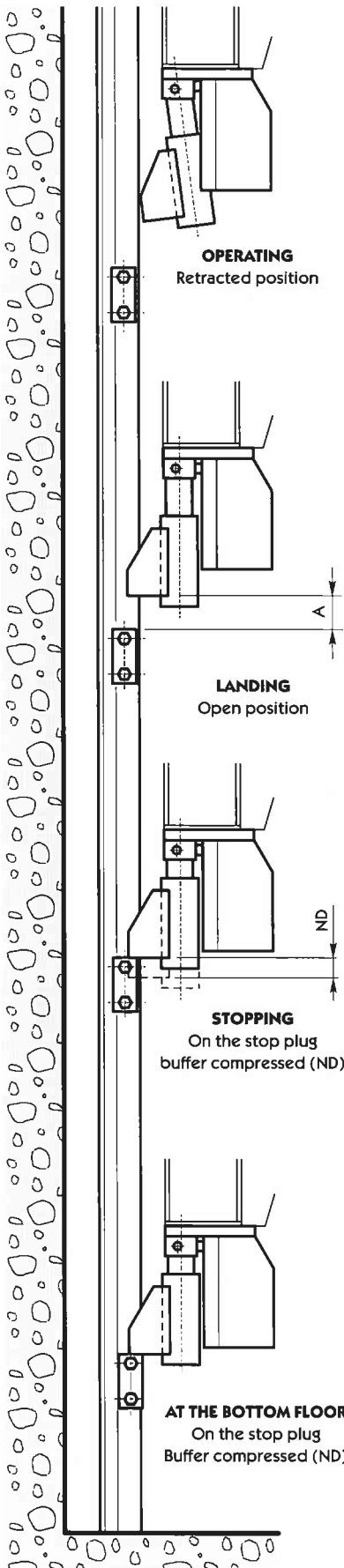

type	Max load [daN]	Max stroke ND [mm]	A max [mm]
NS 40/50	4000	50	70
NS 70/100	7000	100	20

SOLENOID

100 W - 230 Vca 50 Hz - 1 phase - 100% ED included 180 V rectifier (120 Vac - 100 Vdc on request)

CONTROL SWITCHES

Retracted position
Stopping position
Prepared buffer

6A microswitch
6A microswitch
6A safety contact

0.85	2066	
0.8	2189	
0.7	2445	2019
0.6	2745	2233
0.5	3050	2468
0.4	3354	2719
0.3	3636	2983
0.2	3869	3249
0.1	4023	3506
0.0	4077	4077
V [m/s]	V x 1.15 rupture valve	V + 0.30 one way restrictor
QNS [daN]		
TYPE NS 40/50		

V rated speed
QNS maximum total load

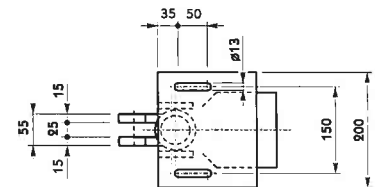
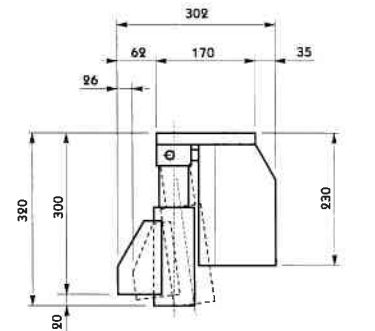

0.85	4799	4262
0.8	4985	4414
0.7	5364	4727
0.6	5742	5051
0.5	6107	5380
0.4	6441	5710
0.3	6727	6029
0.2	6948	6329
0.1	7088	6598
0.0	7136	7136
V [m/s]	V x 1.15 rupture valve	V + 0.30 one way restrictor
QNS [daN]		
TYPE NS 70/100		

V rated speed
QNS maximum total load

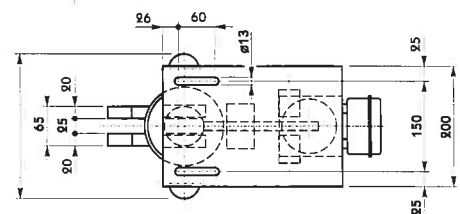
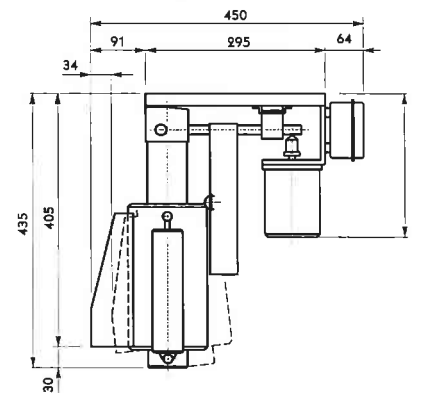

GMV SpA

Via Don Gnocchi, 10 - 20016 PERO (MI) Tel. 02/339.10.680 Fax 02/339.03.79 TLX 335378 GMVI I