

INDEX

<i>Introduction</i>	<i>Page 2</i>
<i>Installation.....</i>	<i>Page 3-4</i>
<i>Trimmings/Adjustments.....</i>	<i>Page 5</i>
<i>Signals – Terminal board</i>	<i>Page 5</i>
<i>General technical information.....</i>	<i>Page 6</i>
<i>Troubleshooting - Fast guide.....</i>	<i>Page 6</i>
<i>Connections schematics</i>	<i>Page 12</i>

INNEHÅLLSFÖRTECKNING

<i>Inledning</i>	<i>Sid 7</i>
<i>Installation.....</i>	<i>Sid 7-9</i>
<i>Inställningar/justeringar.....</i>	<i>Sid 10</i>
<i>Signaler – Anslutningsplint.....</i>	<i>Sid 10</i>
<i>Allmän teknisk information</i>	<i>Sid 11</i>
<i>Felsökning - snabbguide</i>	<i>Sid 11</i>
<i>Kopplingscheman.....</i>	<i>Sid 12</i>

	Soft Starter / Mjukstartare GMV Power Unit / GMV hydraulskåp	I:5.1	
		2003-02-04	2
		RE	2/12

INTRODUCTION

The digital SOFT STARTER is planned to provide a smooth run-up with three-phase induction motors, to reduce the value of the starting current on the mains during start-up; as a consequence, it reduces also the motor torque and mechanical stress on the load. The soft starter allows the separate setting of the acceleration (ramp) as well as the setting of the max. current (torque) during run-up.

Automatic control is provided by a microcontroller.

Automatic protection: Other than the smooth motor start in all load conditions, the microcontroller allows also important support to system-fault analysis and security items: if a mains phase is missing or if the motor is not connected (even 1 phase missing), the soft starter doesn't supply power to the terminals and a relays contact gives the information to the automation cabinet.

Automatic identification of the motor Star-Delta connection: the microcontroller fully supports the operator irrespective of the motor connection: in fact -and without operator intervention- the device recognizes and adapt automatically the control to the motor windings as well as to the mains frequency.

The devices are simply connected between the control panel and the motor. A relay contact is available to drive the possible starting electrovalve or the possible by-pass contactor of DIGISTART.

The control circuit is galvanic isolated from the power circuit and the EMC filter is on board with extreme reduced dimensions.

	Soft Starter / Mjukstartare GMV Power Unit / GMV hydraulskåp	I:5.1	
		2003-02-04	2
		RE	3/12

INSTALLATION

**BEFORE MAKING ANY CONNECTION OR SETTING,
PLEASE MAKE SURE THAT POWER SUPPLY IS OFF !**

NEW POWER UNITS.

The soft starter is delivered connected to the power unit and with a loom for connection to the controller. It is also tested and adjusted for optimal operation.

- 1.1 Fit the soft starter behind the terminal box with existing cap screws.
On smaller power units type Zero, Pal or GL the soft starter has to be fitted on the wall.
- 1.2 Check that the controller is adjusted for GMV Sweden Soft starter.
(Normal only two motorcontactors.)
- 1.3 Connect the loom to the controller se page 12
- 1.4 Test the working of the system by making an up command, when the contactors close the motor will make a smooth run-up. Check for the right rotation sense of the motor. If the motor rotates in opposite sense, invert phase L2 with L3.
If the motor stands still make sure that:
 - The green LED "Power on" and "READY" are on.
 - The red LED "START" is on. There has to be a jumper on terminal 11-12.
 - The LED "FAULT" (alarm signal) is off.
- 1.5 When the motor reaches it's full speed the LED "Top of ramp" lights.

ON EXITING POWER UNITS.

The soft starter is delivered as two parts. One soft start unit and one loom for connection between power unit, soft starter and controller.

- 2.1 Check that you have got the correct soft starter to the power unit. Voltage and Size.

Voltage			
Version	Net	Motor	Comment
230-400V	3x230V	230/400V	Jumper 230V
230-400V	400/230V	400/690V	Jumper 400V
240-415V	415/240V	415/720V	Jumper 400V
500V	3x500V	500/866V	

The jumper in 230-400V and 240-415V version is placed on the main board in the soft starter. In the lower right corner.

Size				
kW	230V	400V	415V	500V
4.7	60A	60A	60A	60A
5.8	60A	60A	60A	60A
7.7	60A	60A	60A	60A
9.5	60A	60A	60A	60A
11.0	60A	60A	60A	60A
12.5	60A	60A	60A	60A
14.7	60A	60A	60A	60A
18.4	100A	60A	60A	60A
22.0	100A	60A	60A	60A
29.4	100A	60A	60A	60A
36.8	N. A.	100A	60A	60A
44.1	N. A.	100A	100A	60A
51.5	N. A.	100A	100A	100A
58.5	N. A.	100A	100A	100A

6mm²
"
"
10mm²
"
"
16mm²
"
25mm²
35mm²

	Soft Starter / Mjukstartare GMV Power Unit / GMV hydraulskåp	I:5.1	
		2003-02-04	2
		RE	4/12

- 2.2 Fit the soft starter behind the terminal box with existing cap screws.
On smaller power units type Zero, Pal or GL the soft starter has to be fitted on the wall.
- 2.3 Connect the loom to the Power unit terminal box, soft starter and controller se page 12.
When the lift is originally equipped with star/delta start the controller has to be modified to direct start. See the electrical diagram on page 12.
It's recommended to have a delay of 0.5-0.8sec to VMP-valve.
Or use the "Top of Ramp" relay to delay the VMP-valve at start.

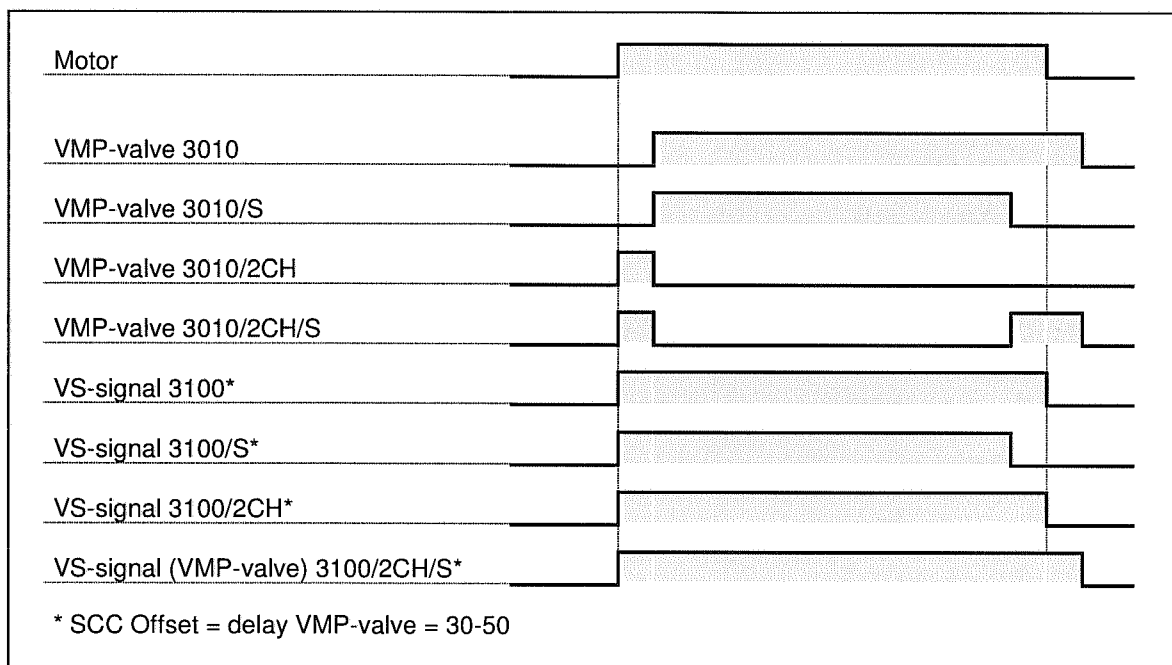

N.B.

In the 60A version the wire marked U has to go through the current transformer.

- 2.4 Recommended adjustments of trimmers
ILIM = max. clockwise.
ST = 3 o clock
ACC = max counter-clockwise
DEC = not used.
- 2.5 Test the working of the system by making an up command, when the contactors close the motor will make a smooth run-up. Check for the right rotation sense of the motor. If the motor rotates in opposite sense, invert phase L2 with L3.
If the motor stands still make sure that:
- The green LED Power ON and READY are on.
 - The red LED START is on. There has to be a jumper on terminal 11-12.
 - The LED FAULT (alarm signal) is off.
- 2.6 When the motor reaches it's full speed the LED "Top of ramp" lights.

	Soft Starter / Mjukstartare GMV Power Unit / GMV hydraulskåp		I:5.1	
			2003-02-04	2
			RE	5/12

TRIMMINGS/ADJUSTMENTS

There are 4 trimmers to set the soft starter to an optimal system performance:

Name	Function	Range	Recommended value	Adjustment.
ILIM	Current limit	60A version=120A 100A version=200A		Max clockwise
ST	Initial voltage	25 –75 %	65%	3 o clock
ACC	Starting time	0.6 – 5 sec.	0.6 sec	Max counter-clockwise
DEC	Stopping time	0.6 – 5 sec.	Not used	

- Rotating **ILIM** trimmer the max current can be set: remember that limiting the current, the torque of the motor is reduced, and the starting time increases.
- Using the **ST** trimmer the starting voltage applied to the motor can be adjusted, and so the starting torque (not linearly). It should be tuned to a minimum value so that the motor starts running immediately; a too high setting avoid the *SOFT effect*.
- With the **ACC** trimmer, the ramp time for motor run-up is adjusted. (Rotating the trimmer clockwise, the ramp time increases).

SIGNALS – TERMINAL BOARD

LED signals

- Power On: Signalises presence of Power Supply
- Fault: It flashes for a missing connection to one or more motor phases, or for a thyristors failure
- Current Limit: It lights when current is being limited to the ILIM value during start-up.
- Start: It is ON when a start command is given. Terminal 11-12.
- Top of Ramp: ON means that the system has finished the run-up ramp and full voltage is provided to the motor.
- Ready: ON means that the device is ready to start

Output relays:

- Top of Ramp: Not used
It closes when the output reaches full voltage; it can be used to activate the VMP-valve (not 2CH valve) or a by-pass contactor
- Relay Ready: Not used
It commutates when the soft starter is correctly operating. It can be used for external indications or to self-keep the by-pass contactor, in so that the contactor itself opens when a protection comes.
- Run: Not Used
It is closed while the motor is running. Useful when deceleration ramp is used to indicate when power supply to the motor stops.

Relay contacts: 8 A 250 Vac AC1



Soft Starter / Mjukstartare
GMV Power Unit / GMV hydraulskåp

I:5.1	
2003-02-04	2
RE	6/12

GENERAL TECHNICAL INFORMATION

Main power supply	See table on page 3
Frequency:	50 ÷ 60 Hz (± 10%) (automatic setting)
Temperature:	0 ÷ 40 °C
Altitude:	1000 m s.l. -1% every 100 m over
Protection:	IP20
Cooling system:	Natural cooling
Control power supply:	Delivered from main power
Control circuit:	Digital by microprocessor
Starts/hour:	60
starting voltage:	25% ÷ 75% of mains voltage
Starting time:	0,6 ÷ 5 secs
Deceleration time:	0,3 ÷ 5 secs
Failure detection:	Lack of motor phase, lack of line voltage, motor not connected, defective thyristor.
Ultra-fast fuses:	For protection of power part, ultra-fast fuses need to be included

Attention: The control circuit is **Galvanic isolated** from the power circuit.

TROUBLESHOOTING - FAST GUIDE

LED	Signals	Conditions	Actions
All	Off	No power supply, no mains	Check the line (L1, L2, L3) and correct selection of the voltage jumper
Power ON Ready	On On	Soft starter ready to start	
Power ON Ready Fault	On Off Flashing	Thyristors failure or lack of one or more phases	Check the motor connection
Power ON Ready Start	On On On	Soft starter is accelerating	
Power ON Ready Start Current limit Top of Ramp	On On On On Off	Current limiter is working, the max voltage isn't reached yet.	
Power ON Ready Start Top of Ramp	On On On On	Soft starter at regime. Relay "Top of Ramp" closed.	

Controller Apparatskåp

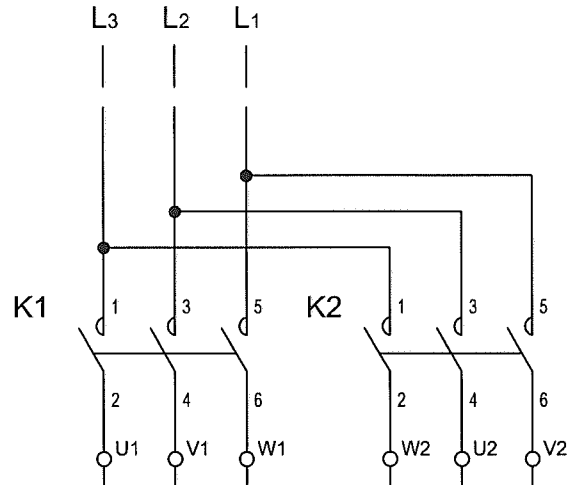
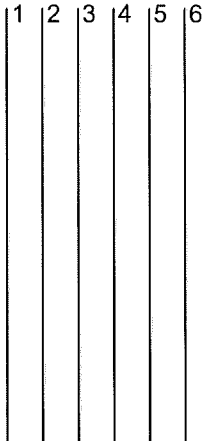
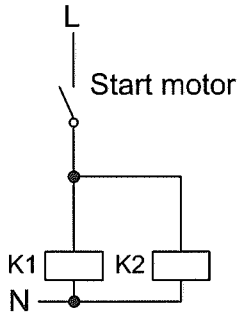

Power Unit Hydraulskåp

Thermistor / Termistor

Valve- or oil heater /
Ventil- eller olje-värmare

Oil temp / Oljetemperatur

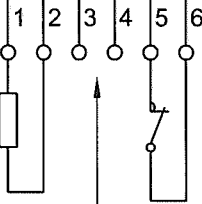

Soft Starter Mjukstartare

Current transformer

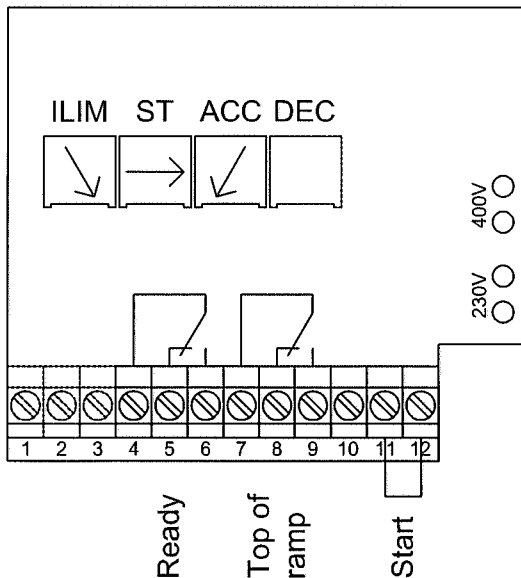
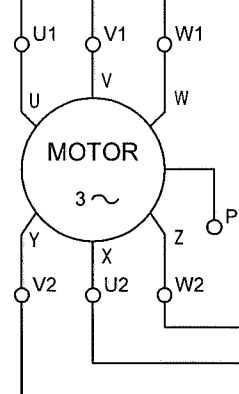
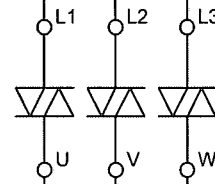

THIS DOCUMENT IS EXCLUSIVE
OWNERSHIP OF GMV
IT IS PROHIBITED TO REPRODUCE
OR DIVULGE IT.

