

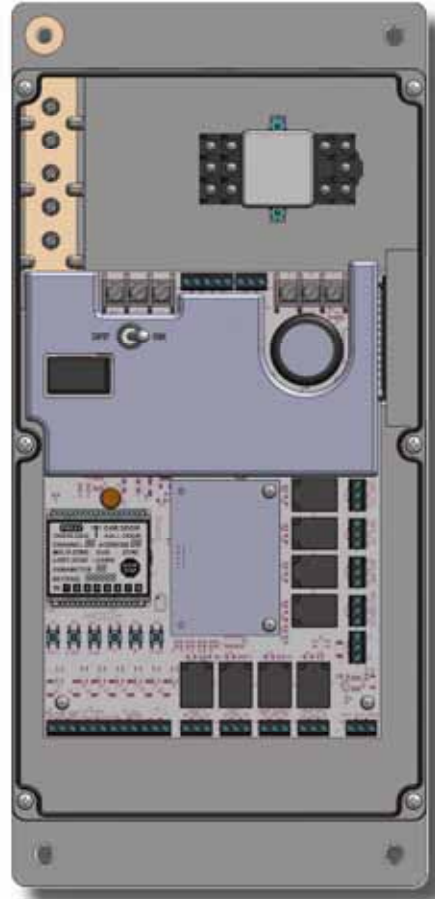

THE PEELLE COMPANY
FREIGHT DOORS | CAR GATES | CAR ENCLOSURES

GUIDE 224



PEELLE WIRELESS DOOR CONTROLLER

CONTROL SYSTEM & INTERFACE GUIDE

VSD | VERTICALLY
SLIDING
DOORS

April 2011

TABLE OF CONTENTS

Section

- I. Safety Warning
- II. Introduction
- III. Technical Specifications
- IV. Getting Familiar With the Controller
- V. Landing Door Controller Installation
- VI. Car Door (Gate) Controller Installation
- VII. Power and Motor Connections
- VIII. Control Interface Connections
- IX. Initial Setup and Learning
- X. Using the LCD Display
- XI. Parameter List
- XII. Limited Warranty

Figures

- 1. Control Layout
- 2. Landing Door Installation
- 3. Car Door Installation
- 4. AC Line Connection
- 5. Encoder Connection
- 6. Door Motor Connection
- 7. Car Gate and Ret Cam Motor Connection
- 8. Landing Input Connections
- 9. Elevator Control Connections
- 10. Output Relays
- 11. Slave Connection
- 12. On-board User Buttons
- 13. Initial Setup Parameters
- 14. Learn Sequence
- 15. Door Type, Channel and Address
- 16. Radio Communication and Overload
- 17. EUD, ZONE and MULTI ZONE
- 18. IN [INDICATOR]
- 19. Door Motion Profiles
- 20. Door Line and Channel Addresses

I. SAFETY WARNING

Definition of Safety Warning Symbols



Electrical Hazard Warning Symbol – Failure to observe this warning could result in electrical shock or electrocution.



Operational Hazard Warning Symbol – Failure to observe this warning could result in dangerous or unsafe conditions.



This product should be installed and serviced by a qualified elevator technician familiar with its operation and hazards involved. Proper installation which includes mounting, wiring, fusing and grounding can reduce the chance of electrical shocks, shorts or fires in this product or electric products such as motors, encoders, switches or relays used with this product. Proper safety procedures must be followed when working with this controller during installation and with control under power. This product is constructed of materials (plastics, metals, carbon, silicon, etc.) which may be a potential hazard. Proper shielding and grounding of this product is necessary to reduce the emissions of radio frequency interference (RFI) which may adversely affect sensitive electronic equipment. If further information is required on this product, contact the Sales Department. It is the responsibility of the elevator equipment and installer to supply this Safety Warning of this product to the end user responsible. (Effective 08/2009)

Electrical Wiring: Wire controller in accordance with the National Electrical Code, Canadian Electrical Code, European Norms and/or any other local codes that apply.

General Contractor Note: A separate fuse disconnect switch is required for the door controllers. Provide a 208-240V AC, 50/60 Hz, 10 A, 1 phase circuit with a fused disconnect switch located in the machine room. Use 10 amp “slow blow” fuses or circuit breakers. A maximum of 10 controllers can be wired per circuit. If there are more than 10 doors including Landing Doors and Car Doors, a second circuit will be required.



The enclosure supplied is non-metallic and does not provide grounding between conduit connections. Use grounding bushings or jumper wires.

Note: This equipment has been tested and found to comply with the limits for a Class A digital device, pursuant to part 15 of the FCC Rules. These limits are designed to provide reasonable protection against harmful interference when the equipment is operated in a commercial environment. This equipment generates, uses, and can radiate radio frequency energy and, if not installed and used in accordance with the instruction manual, may cause harmful interference to radio communications. Operation of this equipment in a residential area is likely to cause harmful interference in which case the user will be required to correct the interference at their own expense.

Modifications not expressly approved by the manufacturer could void the user's authority to operate the equipment under FCC rules.

II. INTRODUCTION

The Peelle Wireless Door Controller simplifies the installation and commissioning of freight elevator doors. The controller meets or exceeds the requirements outlined in ASME A17.1 / CSA B44 Safety Code for Elevators and Escalators. The integrated variable frequency drive with encoder feedback provides closed loop control for significant improvement over traditional door operation. With preloaded parameters and easy terminal connections, the New Peelle Wireless Door Controller is the easiest door controller in the industry. The revolutionary Wireless Door Controller is located at each landing door and car door (gate). Each controller learns and responds to its dedicated door. Through wireless connectivity the landing door and car door controllers function to operate the door and gate in sequence operation. The interface between the landing door and car door set is accomplished using wireless technology which means that the elevator controller interfaces to the car door controller only. Connections are made on top of the car just like a passenger door controller. There is no machine room equipment involved. All components are contained within the hoistway.

Features

- Wireless communication between landing door and car door controllers
- Plug & Play components for the fastest installation times
- Self-learning control setup with encoder feedback
- Pre-adjusted parameters for most applications
- LCD display on control board with diagnostics
- VVVF closed loop drive for energy savings efficiency
- Integrated functional housing for fast installation
- Significant increase in door lifetime with smooth operation
- Operates 3-phase motors up to 0.75kW

How it works...

After installing the door and connecting the control system and components, door operation in independent **IND** mode is available. Doors will open and close according to commands on the on-board OPEN and CLOSE buttons. Using the on-board parameter buttons, the controller is setup for either a LANDING DOOR (Ld) or a CAR DOOR (Cd). Then a CHANNEL is selected for each line of doors/gate (i.e. front, rear) followed by a unique address for each LANDING DOOR controller. The controller is set to LEARN (Lr) mode at which time the opening is automatically learned by the controller. Once complete the operation can be set to Automatic **AUTO** mode and is ready to run.

Using a wireless connection between the controllers within each channel, commands to and from the elevator controller are communicated in order to provide proper door and gate sequence operation. Door zones and emergency unlocking devices are also checked and confirmed using the wireless connection.

III. TECHNICAL SPECIFICATIONS

Technical data	Specification
Input Power	5.5 A @ 240 V, 1500 W
Supply Voltage	208-240 Vac, 50-60 Hz, 1~ (L, N, PE)
Output to Motor	0-220 V AC, 0...60 Hz (variable), 3~ (U, V, W)
Output Power	0.75 kW (1 HP), 4.2 A Max
Digital Inputs	7 provided, 12-30 V AC or DC
Encoder Input	Incremental, NPN, 24 VDC, 400 PPR
Relay Outputs	8 provided, Form C, 125 Vac, 10 A Max
Input/Output Indicators	LED
Enclosure Protection	IP 20 (IP 65 optional)
Temperature Range	-10 to 40 deg. C
Dimensions	200 mm x 430 mm x 85 mm (W x H x D)
Mounting Method	4 screw holes on outside perimeter
Wireless Network	IEEE 802.15.4
Wireless Network Range	100 m
User Interface	Onboard pushbuttons with visual display
Visual Display	2" x 1.5" LCD (4 COM x 32 Segments)
Parameters	Max. 100 user adjustable with factory presets
Learn Adjustment	Automatic with user parameter
Door Address	User selectable parameter
Car or Hall Door Type	User selectable parameter
Fail Safe Condition	Door stop if communication lost
Standards	ASME-A17.1/CSA-B44 ASME-A17.5/CSA-B44.1 EN 81 EN 12016
Markings	ETL Mark by Intertek Testing Services

IV. GETTING FAMILIAR WITH THE CONTROLLER

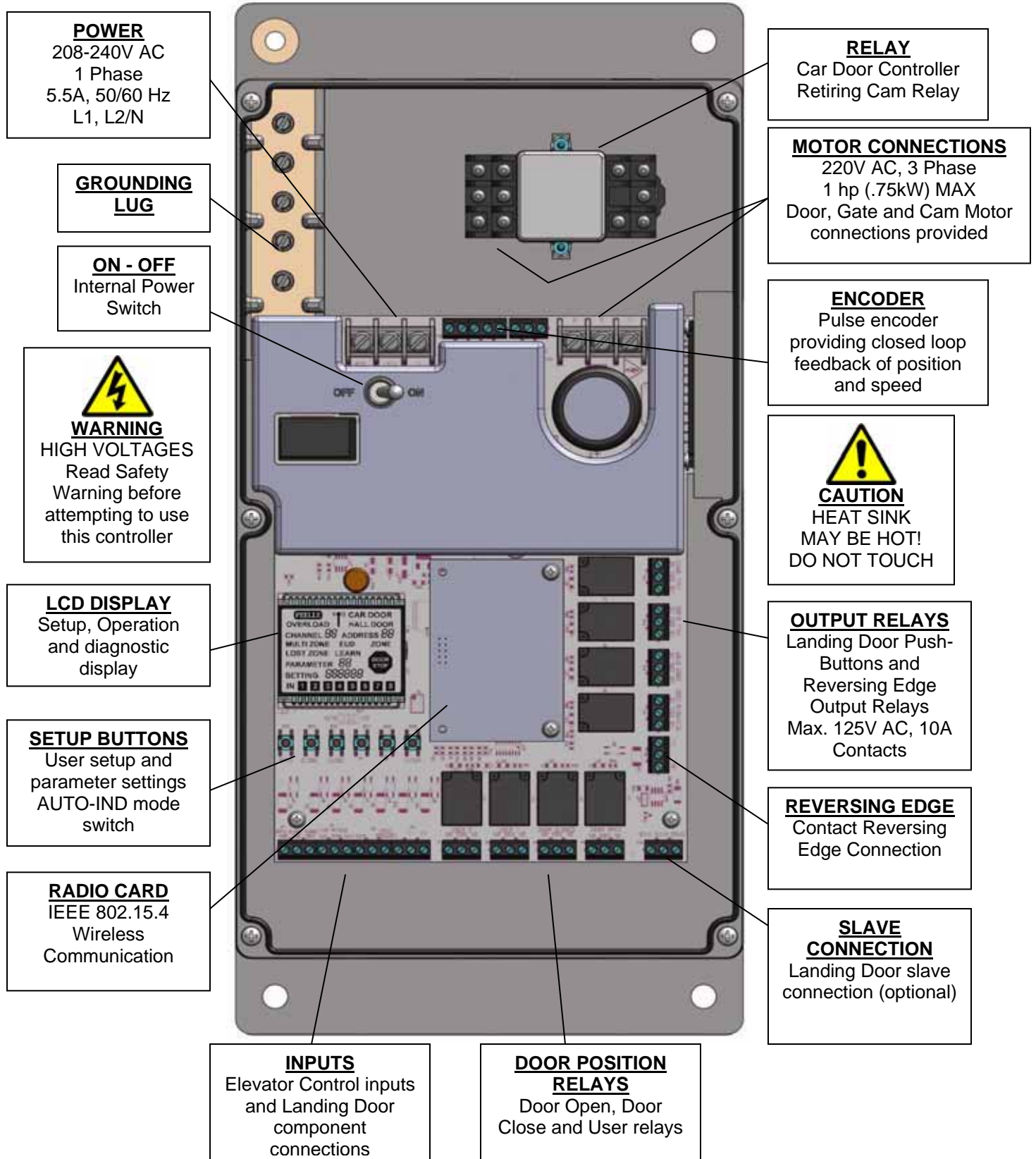

V. LANDING DOOR CONTROLLER INSTALLATION

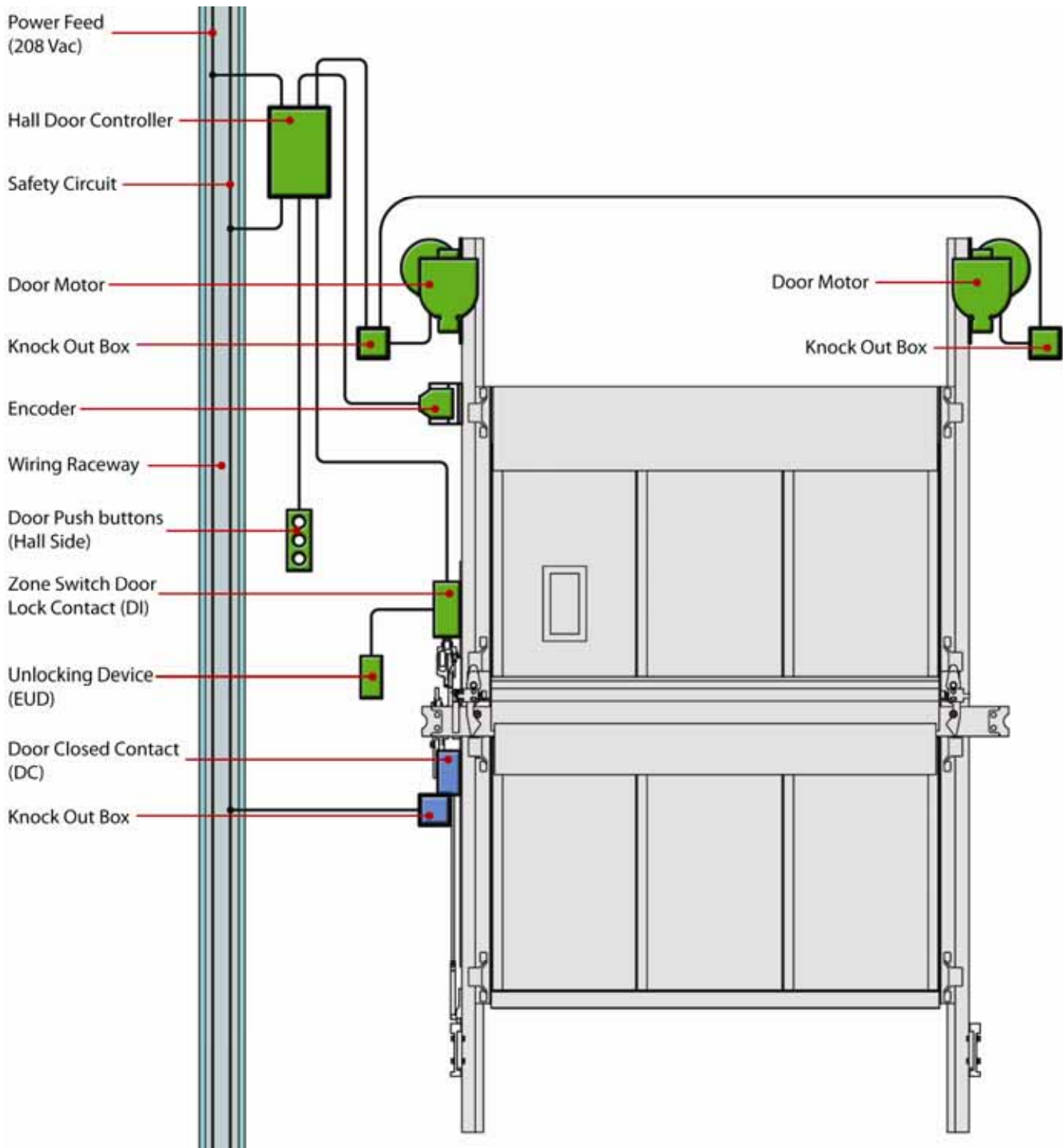

VI. CAR DOOR (GATE) CONTROLLER INSTALLATION

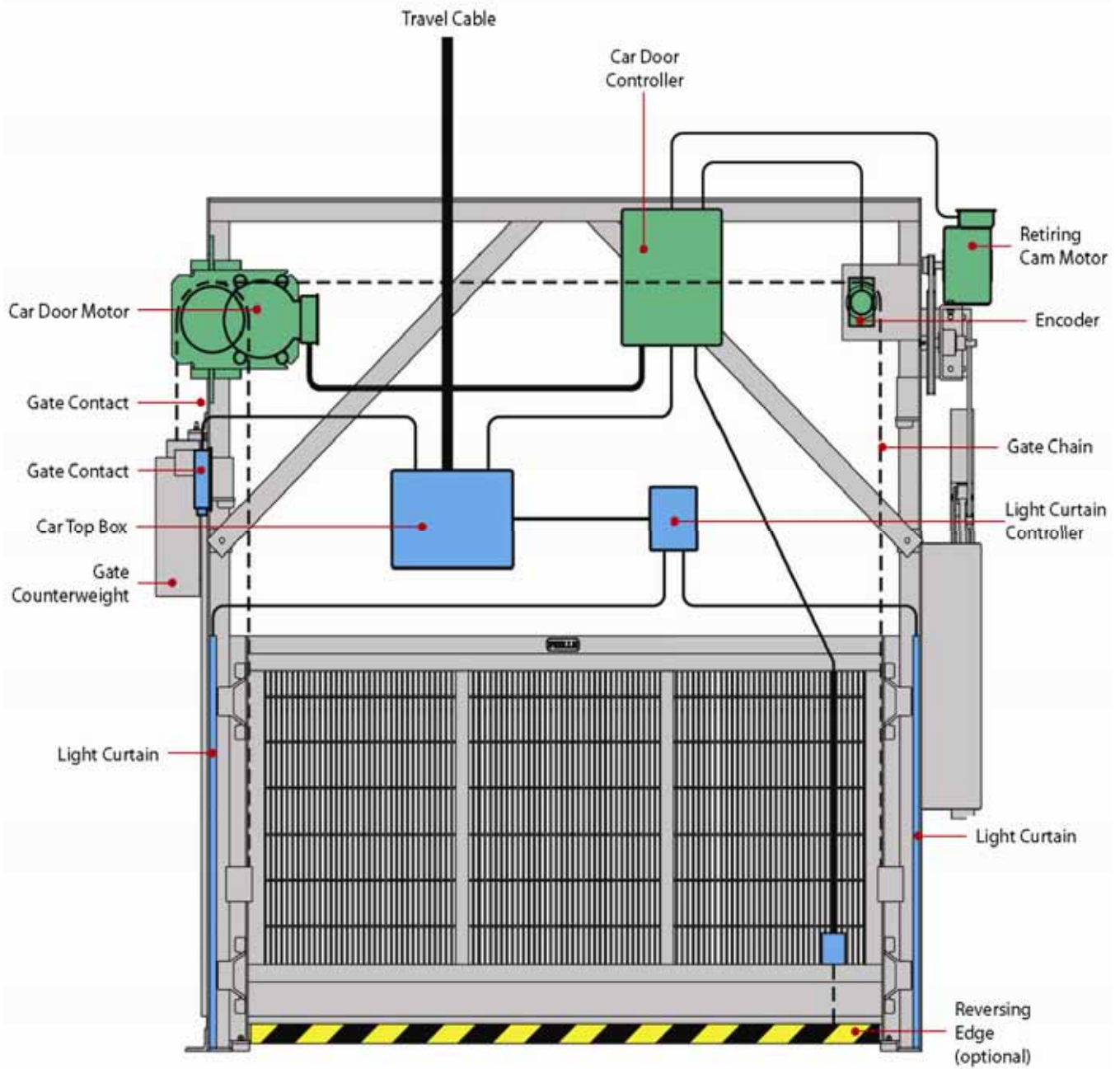

VII. POWER AND MOTOR CONNECTIONS

Power (FIG. 4)

Connect controllers in accordance with National Electrical Code, Canadian Electrical Code, and other local codes that apply. Power branch circuit should come from machine room disconnect 10 amp circuit. Maximum 10 controllers per circuit. Use #14AWG copper wire for power connection.

- ON/OFF switch disconnects both lines
- If neutral is not used, main disconnect must break both lines.

Encoder (FIG. 5)

Install and wire encoder near the controller. Do not extend the encoder wire. Encoder direction does not matter; direction is established during the LEARN setup. Connect the wires from the encoder directly to the terminal blocks.

Landing Door Motors (FIG. 6)

Wire both door motors in parallel. Use #18AWG wire in conduit for motor connection. Do not combine motor wires with control wires in same conduit.

Note: Peelle door motor low speed winding is not used. Cap black wires separately (T4-T5).

Car Door (Gate) and Retiring Cam Motor (FIG. 7)

Car door motor and retiring cam motor are driven by the same controller. A relay is provided in the controller to switch between the car gate and retiring cam motor operation. Use #18AWG wire in conduit for motor connection.

Do not combine motor wires with control wires in same conduit.

Note: Peelle car gate motor low speed winding is not used. Cap black wires separately (T8-T9).

FIG. 4 – AC LINE CONNECTION

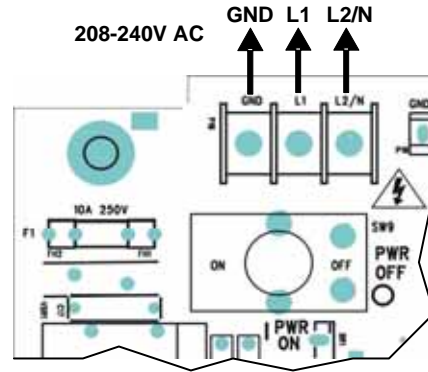

FIG. 5 – ENCODER CONNECTION

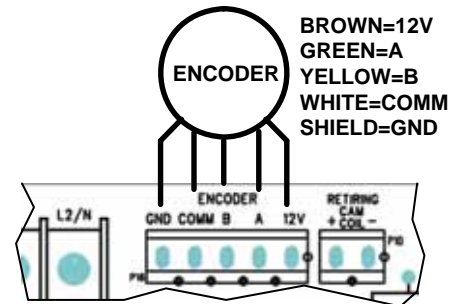

FIG. 6 – DOOR MOTOR CONNECTION

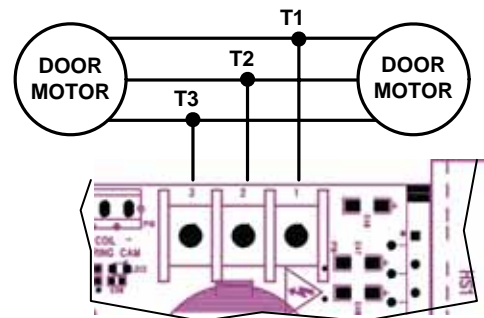
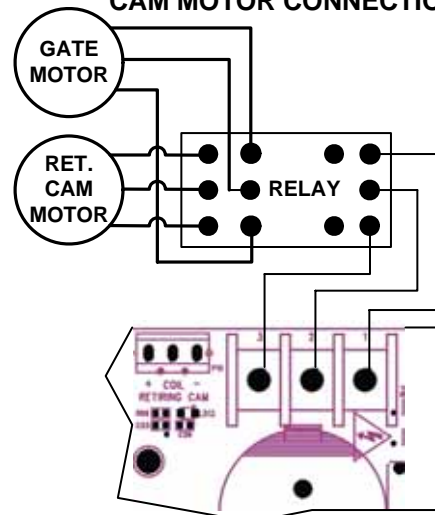

FIG. 7 – CAR GATE AND RETIRING CAM MOTOR CONNECTION



VIII. CONTROL INTERFACE CONNECTIONS

Landing Door Input Connections (FIG. 8)

Input Voltage Source

Use board power $V+ / V-$ (12Vdc). Connect the source $V-$ to the INPUT COM. Connect all devices through $V+$ source.

[1] **HDO - HALL DOOR OPEN BUTTON** – Where provided, wire landing station door OPEN pushbuttons as shown. When elevator car is within floor ZONE, pushbutton inputs will be transmitted to the Car Door controller for connection to elevator control.

[2] **HDC - HALL DOOR CLOSE BUTTON** – Where provided, wire landing station door CLOSE pushbutton as shown. When elevator car is within floor ZONE, pushbutton inputs will be transmitted to the Car Door controller for connection to elevator control.

[3] **ZNS - ZONE SWITCH** – The landing door ZONE SWITCH located in top of interlock box activates the controller for the Landing door at which the elevator car is located.

[4] **EUD - EMERGENCY UNLOCKING DEVICE** – The landing door EMERGENCY UNLOCKING DEVICE is located on the landing side and contains a toggle switch which must be wired to the controller. **NOTE:** Only in jurisdictions not requiring unlocking devices, a jumper needs to be added in lieu of the EUD switch.

[5] **STOP - DOOR STOP BUTTON** – Where provided, wire landing station door STOP pushbutton as shown. Default setting for the controller is a normally open (NO) stop button. If normally closed (NC) stop button is provided, parameter setting can be changed (see List of Parameters).

[6] **AUX1** – Not used

[7] **AUX2** – Not used

FIG. 8 – LANDING DOOR INPUT CONNECTIONS

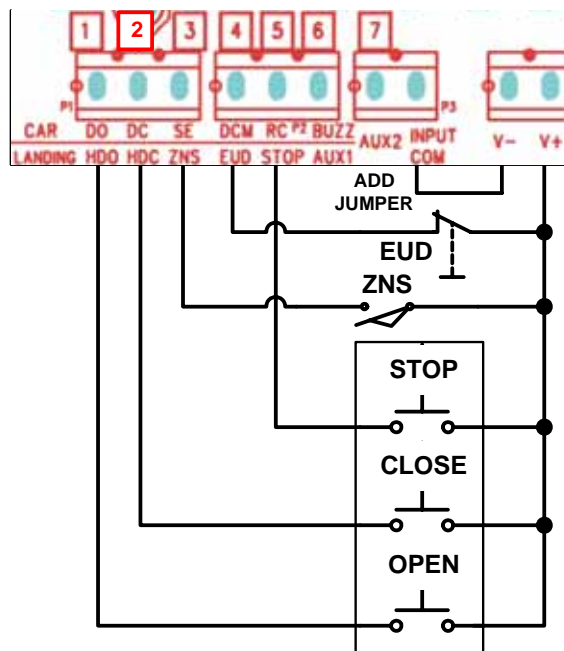

Car Door Input Connections – Elevator Control (FIG. 9)

NOTE: Elevator controller interface connections to the Car Door Controller ONLY. Do NOT connect to landing door controller.

Input Voltage Source

Use board power $V+ / V-$ (12Vdc) or 12-30V AC or DC. Connect the source COM to the INPUT COM. The polarity of a DC source COM can be + or – but must be opposite of the source.

[1] **DO - DOOR OPEN** – Door open initiation requires constant signal until the landing door and car door are fully open.

[2] **DC - DOOR CLOSE** – Door close initiation requires constant signal until the car door and landing door are fully closed.

[3] **SE - GATE SLOW SPEED** – Slow speed initiation required with DOOR CLOSE until door and car gate are fully closed. Used with Firefighters Emergency Operation Phase 1 Recall.

[4] **DCM - FAST OPEN/CLOSE** – Fast initiation required with DOOR OPEN and DOOR CLOSE until door and gate are fully opened or closed. Used with Firefighters Emergency Operation for simultaneous door and gate operation.

[5] **RC - RETIRING CAM** – Retiring Cam initiation required to lift cam and lock the doors. Retiring cam initiation ON to move the elevator car, OFF whenever car is stopped.

[6] **BUZZ - CLOSE WARNING BUZZER** – Close Warning Buzzer initiation required 5 seconds before automatic closing and whenever doors are closing whether by automatic initiation or constant pressure close.

[7] **AUX2 - Not used**

FIG. 9 – CAR DOOR INPUT CONNECTIONS ELEVATOR CONTROL

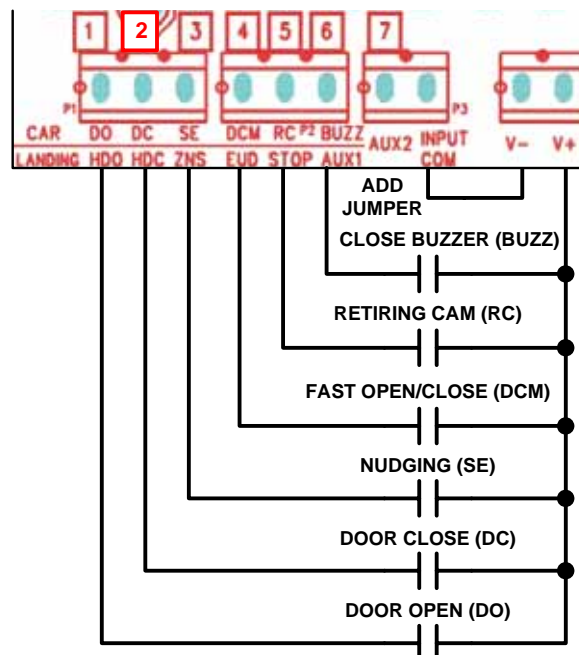

SLAVE CONNECTION (FIG. 10) -

Where used with super high torque opposite side motor connection option, wire communication between the master and slave controllers of the same landing door.

FIG. 10 – SLAVE CONNECTION MASTER SLAVE

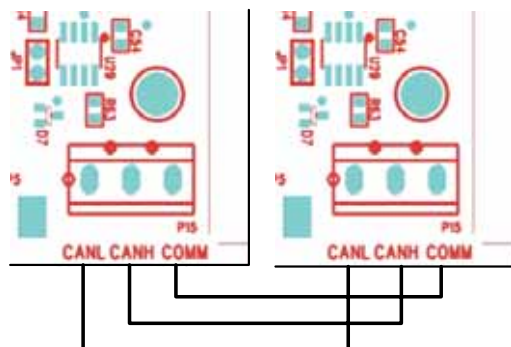

Car Door Output Connections – Elevator Control (FIG. 11)

NOTE: Elevator controller interface connections to the Car Door Controller ONLY. Do NOT connect to landing door controller.

Output Relay Contacts

All contact are Form C rated at maximum 125VAC 10A.

HALL OPEN – When the elevator car is at a landing zone, the Hall Door Open button (HDO) of the adjacent Landing door controller will be transmitted wirelessly to the car door controller HALL OPEN relay.

HALL CLOSE – When the elevator car is at a landing zone, the Hall Door Close button (HDC) of the adjacent Landing door controller will be transmitted wirelessly to the car door controller HALL CLOSE relay.

DOOR STOP – When the elevator car is at a landing zone, a Door Stop (STOP) initiated by the adjacent landing door controller or a stop initiated by EUD or ZNS will be transmitted wirelessly to the car door controller DOOR STOP relay.

FIG. 11 – OUTPUT CONNECTIONS

REVERSING EDGE – The reversing edge (RE) output of the car door controller is provided by the REVERSING EDGE relay.

BUZZER – Mount the buzzer to the car door controller box in the knock out labeled BUZZER. Make sure buzzer is audible from within the elevator car. Wire the buzzer as shown in FIG. 11.

DOOR OPEN – The fully open position of the door is provided by the DOOR OPEN relay. When the car is at a landing zone, the car door controller DOOR OPEN will indicate when both the car door and the adjacent landing door are fully open.

Note: relay condition on power up is determined by Parameter 97.

DOOR CLOSE – The fully closed position of the door is provided by the DOOR CLOSE relay. When the car is at a landing zone, the car door controller DOOR CLOSE will indicate when both the car door and the adjacent landing door are fully closed.

Note: relay condition on power us is determined by Parameter 97.

USER 1 and USER 2 – The USER output relays are programmable according to Parameters 62 and 63. See Parameter List. The default setting for USER 1 is to turn on when the door is 3/4 open and USER 2 to turn on when the door is 3/4 closed.

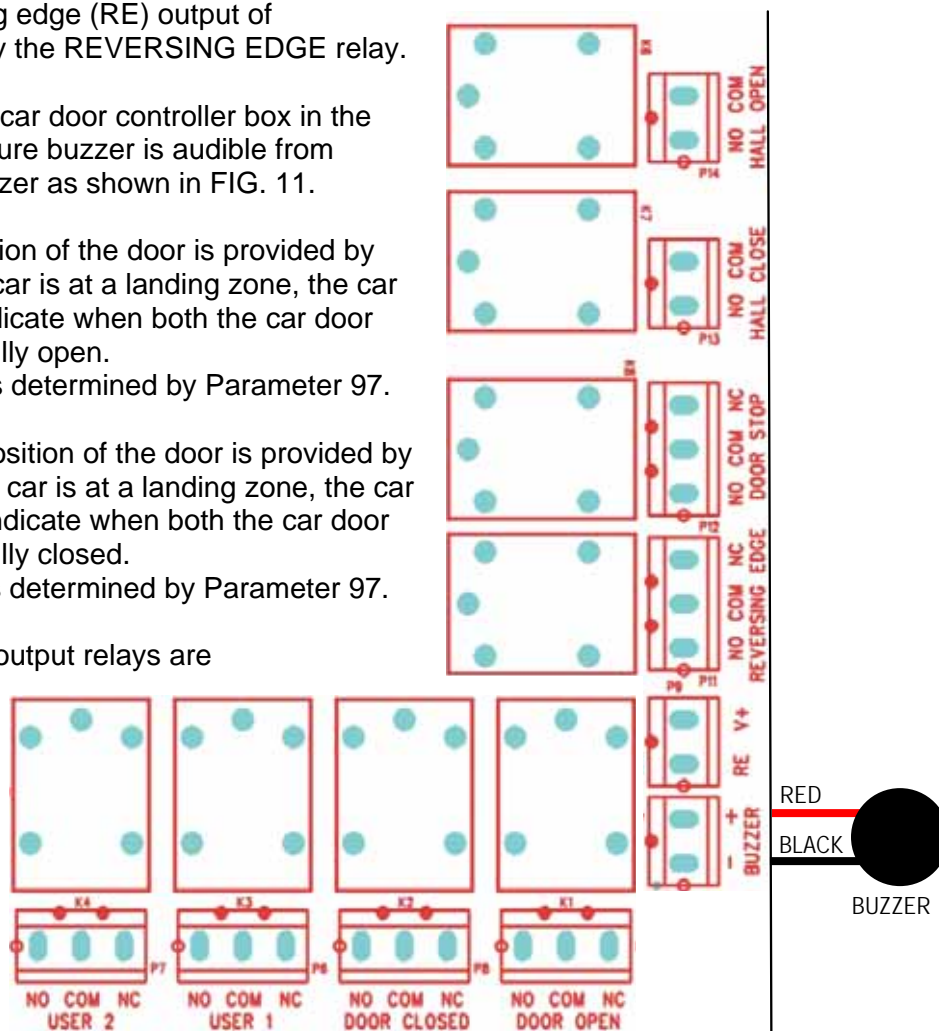

IX. INITIAL SETUP AND LEARNING

Operation Modes (FIG. 12)

INDEPENDENT OPERATION – Set the **AUTO<>IND** switch to **IND** for independent door operation. Wireless communication is disabled, parameters are read and write enabled and board controller door operation is available in **IND** mode.

FIG. 12 – ON BOARD USER BUTTONS

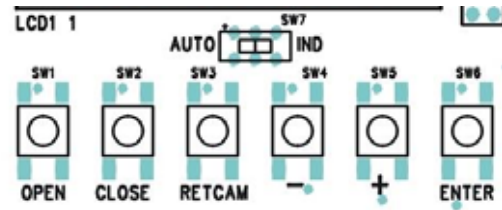

AUTOMATIC OPERATION – Set the **AUTO<>IND** switch to **AUTO** for automatic door operation. Wireless communication is enabled and doors will respond to commands from the elevator controller through the Car Door Input Connections. The SETUP and LEARN need to be established first. **Note:** parameters can be view in AUTO mode but are read-only.

User Parameter Settings (Refer to FIG. 12 and 13)

SETTING PARAMETERS - The parameters are set using the -, +, and ENTER buttons and viewed on the LCD.

- Under normal operating conditions, the display will show the door encoder count.
- Pressing -, +, or ENTER will cause the display to change to show the PARAMETER icon flashing and showing parameter 01 and the SETTING icon to be displayed along with the current setting for parameter 01.
- Pressing - or + will cause the parameter # to change to the next parameter. At the same time, the setting # will change to show the current setting for that parameter.
- Pressing ENTER will change the PARAMETER icon to on steady and the SETTING icon to flash.
- Pressing - or + will now change the setting # for the chosen parameter.
- Pressing ENTER will store the new setting into EEPROM and change the display back to flashing the PARAMETER icon.
- If there is no activity for 20 seconds, the display will switch back to the normal operating display.

OPEN, CLOSE, RETCAM BUTTONS – Use the OPEN, CLOSE and RETCAM on board buttons to simulate the operation of the door for the same input connection.

FIG. 13 – INITIAL SETUP PARAMTERS

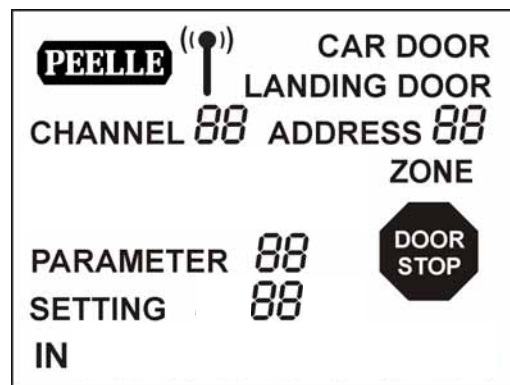

Setup and Learn the Opening (FIG. 14)

NOTE: USE THE DOOR LINE CHANNEL AND ADDRESS CHART (FIG. 20) TO DOCUMENT THE SETTINGS.

Before beginning the setup and learn, make sure the door is adjusted and runs freely by hand in the door guides without binding or sticking. Make sure Landing Door interlocks are mechanically unlocked.

1. Set the controller to independent **IND** on the **AUTO<>IND** switch.
2. Set **PARAMETER 02, Door Type**, to either Car Door **Cd**, Landing Door **Ld** or Slave **SL** (see Slave Connection) in the setting field according to the type of door for that controller.
3. Set **PARAMETER 03, Channel**, to a unique channel number setting for each line of doors. A line of doors is defined as one Car Door and all the associated Landing Doors corresponding to that Car Door entrance. Every controller in that line needs to receive the same channel number setting.
4. Set **PARAMETER 04, Floor Address**, to a unique address number setting for each Landing opening. Start in sequence from the lowest landing as setting **01** and move upward. It is OK to skip a sequence number but do not skip more than 2 numbers in the sequence. **00** is not an address.
Note: Parameter 04 only applies to Landing Doors. If Parameter 02 has been set to Car Door **Cd**, Parameter 04 will not be displayed.
5. Set **PARAMETER 10, Learn**, to **Lr** in the setting field to begin learn opening sequence. The learn opening cycle will first close the door then open the door fully. The opening size and final positions are memorized by the controller according to the fully closed and fully open stall position of the door and direction of the encoder. The display will show LEARN and the encoder count position during the learn sequence (see **FIG. 14**).
6. Once the learn is complete, test the opening with the OPEN and CLOSE on-board push buttons.
7. Set the controller to automatic **AUTO** on the **AUTO<>IND** switch when finished.

FIG. 14 – LEARN SEQUENCE

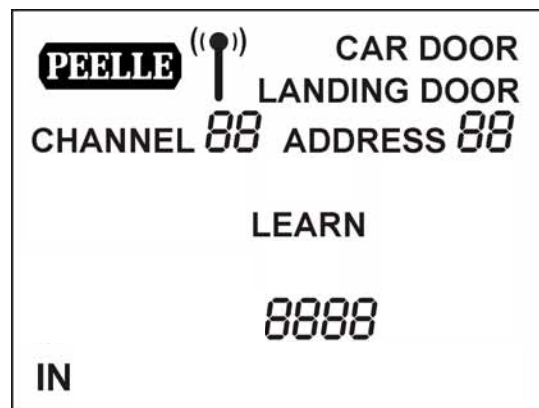

Make sure to reset any Landing Door interlocks that were unlocked during the learn cycle. Reset the Emergency Unlocking Device (EUD) switch if the EUD was accessed.

X. USING THE LCD DISPLAY (FIG. 15-18)

CAR DOOR / LANDING DOOR – Each controller is capable of operating only a single Car Door (Gate) or Landing Door. The setting is displayed in the upper right cornering and is set by Parameter 02.

CHANNEL – Every line of doors must have a unique channel. This means that front and rear doors must have different channels. Lines of doors within a multiple hoistway or adjacent hoistway must also have a different channel. Any line of doors within 100m [300ft] must have a unique channel. The CHANNEL is set by Parameter 03.

ADDRESS – Address only applies to Landing Doors. Each Landing Door within a single line on a CHANNEL must have a unique address. The address should follow in a sequence although it is permissible to skip a maximum of two addresses in sequence. The ADDRESS is set by Parameter 04.

RADIO ANTENNA – The radio antenna will display whenever the controller is on AUTO and the radio is working. The antenna icon will flash if the controller is not communicating with any other controllers and it will be solid when it is in communication. Generally, while the elevator is at a landing zone, the controllers will communicate but while the elevator is travelling between floors, communication is disabled.

OVERLOAD – Overload will be displayed if the motor output exceeds the specification or the motor output has been shorted to ground. The controller will not operate. Overload is reset using Parameter 01 or by cycling power to the controller.

EUD – The EUD indicator will go ON solid when the EUD switch is in the set position (activated) for the door connected to that controller. The EUD indicator will flash for all other controllers in that channel to indicate there is a EUD set at another floor. All EUD switches connected to a CHANNEL must be reset for door operation.

Note: For automatic door operation, ALL the EUD switches have to be in the reset position.

ZONE – The status of the landing zone is shown as ZONE on the display. Once the car is within the landing zone with the retiring cam extended, ZONE input will go ON and ZONE will be displayed.

Note: The zone is required for door and gate operation in automatic mode.

FIG. 15 – DOOR TYPE, CHANNEL AND ADDRESS



FIG. 16 – RADIO COMMUNICATION AND OVERLOAD

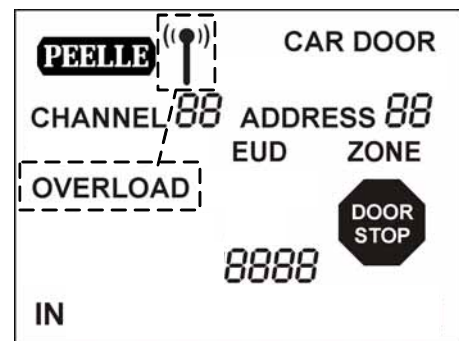
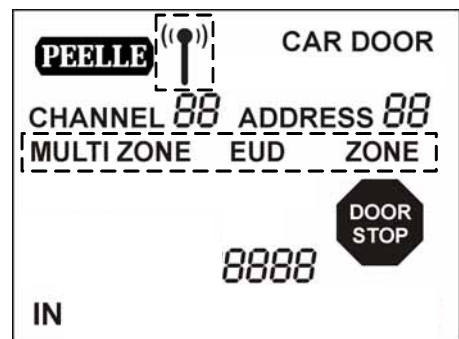

FIG. 17 – EUD, ZONE AND MULTI ZONE



MULTI ZONE – The MULTI ZONE will indicate that two or more Landing Controllers have been activated by the ZONE input. In a “multi zone” situation the controllers are not able to operate the doors because the elevator car can not be at more than one landing.

Note: A single zone is required for automatic door operation.

DOOR STOP – The DOOR STOP indicator will illuminate whenever the drive output stops and will disappear when the motor is running. The DOOR STOP can be used to see if there is output power going to the motor. The DOOR STOP indicator is not the same as the STOP output relay.

ENCODER COUNT – The default counter display will show the count of the encoder of the door position. During the LEARN sequence, a count of zero will be captured for the fully closed position of the door.

INPUT INDICATORS – The input indicators are shown on the LCD screen bottom section as numbers 1 to 7 in squares that correspond to the associated input.

FIG. 18 – INPUT INDICATORS

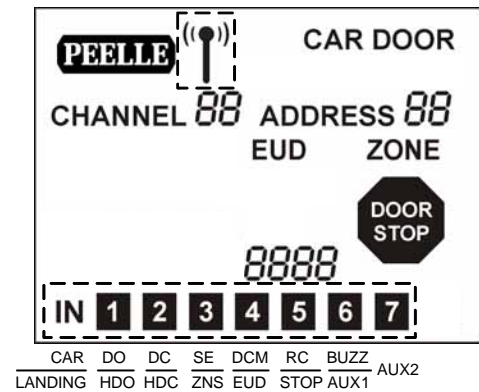

XI. PARAMETERS

FIG. 19 – DOOR MOTION PROFILES

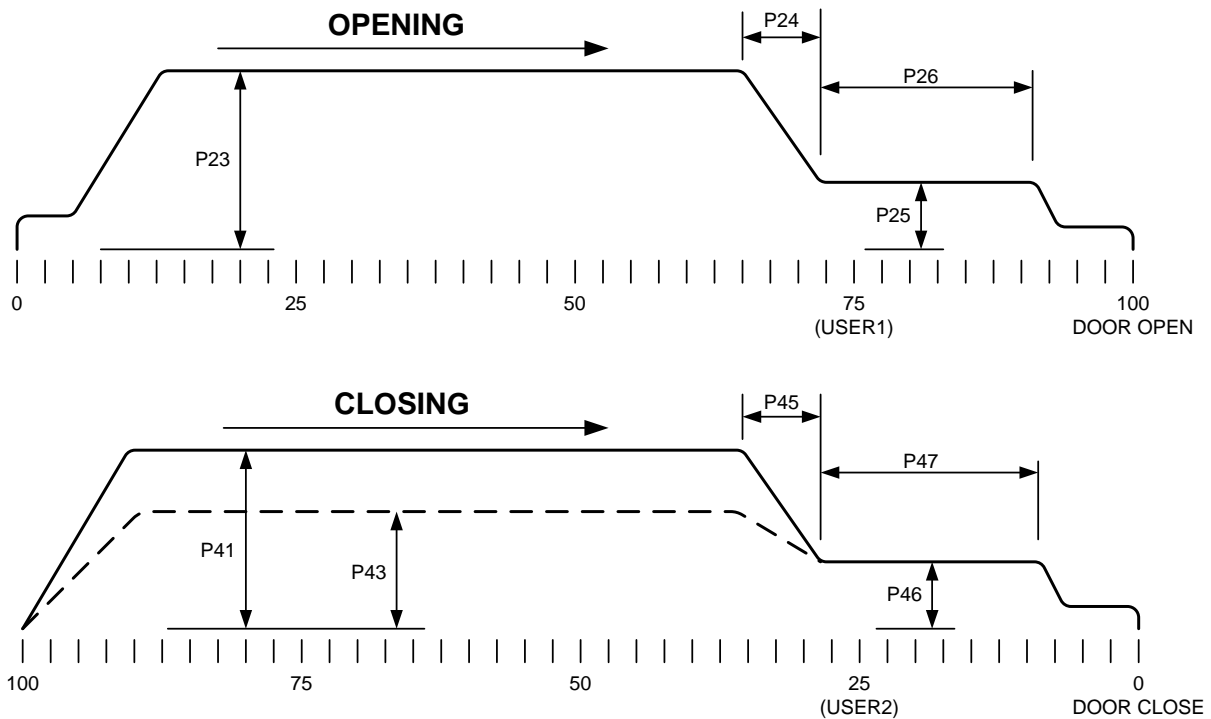

PARAMETER LIST –

Parameter	Description	Range	Landing Pre Set	Car Pre Set
01	Reset Overload (0 = Do not reset, 1 = Reset)	0 - 1	0	0
02	Controller Type: Car Door, Landing Door, Slave	Cd,Ld,SL	Ld	Ld
03	Channel: set a unique <u>Channel</u> for each line of doors	11-22	15	15
04	Floor: set a unique <u>Floor address</u> for each Landing Door (note: 0 is not valid address)	0-30	0	N/A
10	Learn Command: used to learn the opening	Lr or --	--	--
11	Learn Speed: set learn and power-up speed	40-70	40	40
23	Open High Speed: set the opening high speed	20-99	99	99
24	Open Deceleration Zone: set distance of deceleration ramp	0-30	10	10
25	Open Low Speed: set low speed open	20-99	50	30
26	Open Low Speed Zone	0-30	10	10
27	Open Hold Torque: set the hold open torque	0-50	25	15
41	Close High Speed: set the closing high speed	20-99	99	85
42	Close High Speed Torque Limit	30-99	99	99
43	Close Nudging Speed	30-70	N/A	50
44	Close Nudging Speed Torque Limit	30-99	N/A	70
45	Close Deceleration Zone: set distance of deceleration ramp	0-30	10	10
46	Close Low Speed: set low speed close	20-99	50	30
47	Close Low Speed Zone: set distance of low speed zone	0-20	10	10
48	Close Hold Torque: set the hold close torque	0-50	25	15
60	Door Stop Deceleration Rate	1-10	3	3
61	Door Start Acceleration Rate	1-10	3	3
62	USER 2 Close Limit: set position of the user door close limit	70-99	75	75
63	USER 1 Open Limit: set position of the user door open limit	70-99	75	75
64	User Limits Setting: 0 = landing door USER limit + car door USER limit sets USER relay output on car door controller 1 = car door USER limit sets USER relay output on car door controller	0-1	N/A	0
70	Retiring Cam Deceleration Rate	1-10	N/A	3
71	Retiring Cam Acceleration Rate	1-10	N/A	3

80	Software Version	2 digits	Software Version	Software Version
95	Close Input Buzzer Control 1 -- Enabled 0 -- Disabled		N/A	1
96	Hall Stop Push-Button: 0 -- Normally Open 1 -- Normally Closed	0-1	0	N/A
97	Power-Up Settings: 1 – DC = 1, DO = 1; 2 – DC = 1, DO = 0; 3 – DC = 0, DO = 0; If zoned, both DC and DO = 0, regardless of selection. Condition of outputs is established automatically after opening or closing cycle	1-3	3	1
98	Show Cycle Counter	6 digits	Cycle Counter	Cycle Counter
99	Restore Factory Default Settings 0 – Exit without saving 1 – Restore all Motor parameters (#20 –97) 2 – Restore all parameters (#2 – 97)	0-2	0	0

N/A – Not available

DO – DOOR OPEN output

DC – DOOR CLOSED output

Speeds are expressed as a percentage of full speed.

Zone is expressed as a percentage of total travel.

Torque is expressed as a percentage of nominal voltage for corresponding speed.

Parameters 27 and 48 really are speeds used for final stages of profiles.

XII. LIMITED WARRANTY

- a. Peelle warrants to the Customer that goods and services sold will be free from defects in material, workmanship and title and will conform to any mutually agreed upon specifications. If any failure to meet this warranty appears within one year from the date of shipment of the goods or completion of the services, on the condition that Peelle be promptly notified in writing, Peelle will correct any such failure by re-performing any defective portion of the services furnished and supplying conforming goods. If the contract covers installation, repair or maintenance, Peelle will correct the failure by performing any defective service, and either repairing or replacing (at its option) any defective goods furnished and any damaged equipment upon which the service was performed resulting from defective service. If re-performance is not practicable, Peelle will furnish without charge services in an amount essentially equal to those which, in Peelle’s sole judgment, would have been required for re-performance.
- b. The preceding paragraph a. sets for the exclusive remedy for all claims based on failure of, defect in, goods or services sold hereunder, whether the failure or defect arises before or during the warranty period, and whether a claim, however instituted, is based on contract, indemnity, warranty, tort (including negligence), strict liability or otherwise. The foregoing warranty is exclusive and is in lieu of all other warranties whether written, oral, implied or statutory.

FIG. 20 – DOOR LINE CHANNEL AND ADDRESSES

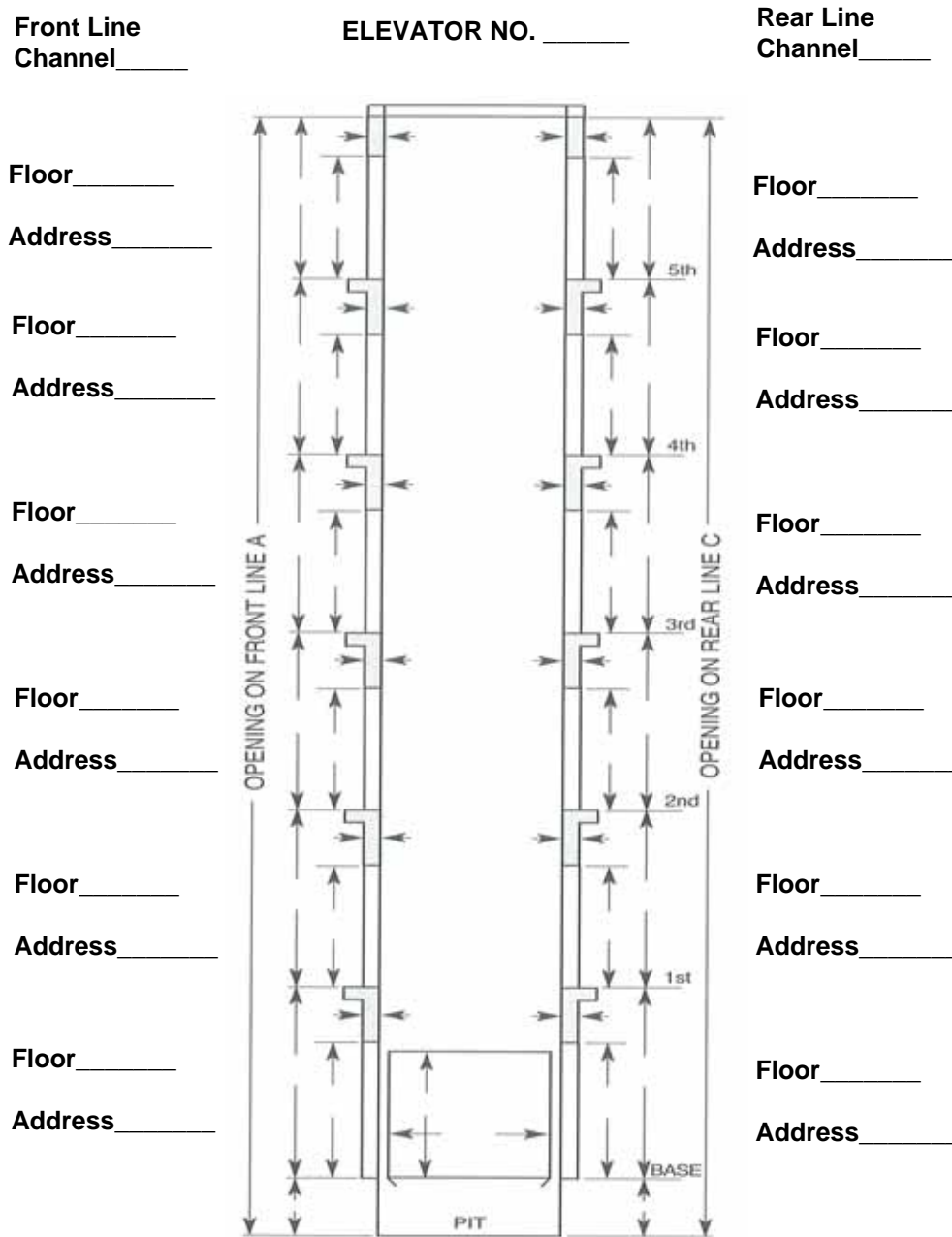

INSTRUCTIONS:

- Give each LINE of doors (i.e. Elev.1:Front, Elev.1:Rear, Elev.2:Front, Elev.2:Rear... etc.) a separate Channel number using Parameter 03.
- All elevators within the same hoistway or separate hoistways within 100m (300ft) of each other must have separate Channel numbers for each of the LINES of doors.
- Give each Hall Door within a Channel a separate Address number Setting starting from 01 at the lowest landing and working up in sequence. You may skip an address in sequence but not more than two in a row.
- Duplicate Addresses are allowed on different Channels but not within the same Channel.
- There are 99 Channels and Addresses and 00 is not available.